

Model BF Square Type Support Unit on the Fixed Side

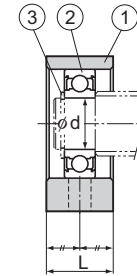
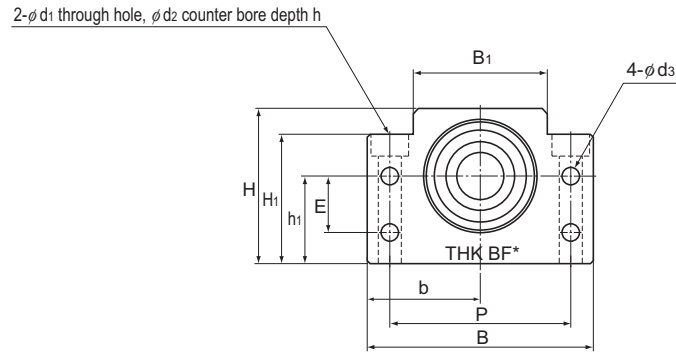

Unit: mm

Model No.	Shaft diameter d	L	B	H	b ±0.02	h ₁ ±0.02	B ₁	H ₁	E	P	d ₃	d ₁	d ₂	h	Bearing used	Snap ring used	Mass kg
BF 10	8	20	60	39	30	22	34	32.5	15	46	5.5	6.6	10.8	5	608ZZ	C8	0.29
BF 12	10	20	60	43	30	25	35	32.5	18	46	5.5	6.6	10.8	1.5	6000ZZ	C10	0.3
BF 15	15	20	70	48	35	28	40	38	18	54	5.5	6.6	11	6.5	6002ZZ	C15	0.38
BF 17	17	23	86	64	43	39	50	55	28	68	6.6	9	14	8.5	6203ZZ	C17	0.74
BF 20	20	26	88	60	44	34	52	50	22	70	6.6	9	14	8.5	6004ZZ	C20	0.76
BF 25	25	30	106	80	53	48	64	70	33	85	9	11	17.5	11	6205ZZ	C25	1.42
BF 30	30	32	128	89	64	51	76	78	33	102	11	14	20	13	6206ZZ	C30	1.97
BF 35	35	32	140	96	70	52	88	79	35	114	11	14	20	13	6207ZZ	C35	2.22
BF 40	40	37	160	110	80	60	100	90	37	130	14	18	26	17.5	6208ZZ	C40	3.27

Note) The area marked with "*" is imprinted with a numeric character(s) as part of the model number.

Part No.	Part name	No. of units
1	Housing	1
2	Bearing	1
3	Snap ring	1