

Model CFH-A(Eccentric Cam Follower with Hexagon Socket (Cylindrical Outer Ring)),
 Model CFH-M-A (Made of Stainless Steel)
 Model CFH-R-A(Eccentric Cam Follower with Hexagon Socket (Spherical Outer Ring)),
 Model CFH-MR-A (Made of Stainless Steel)

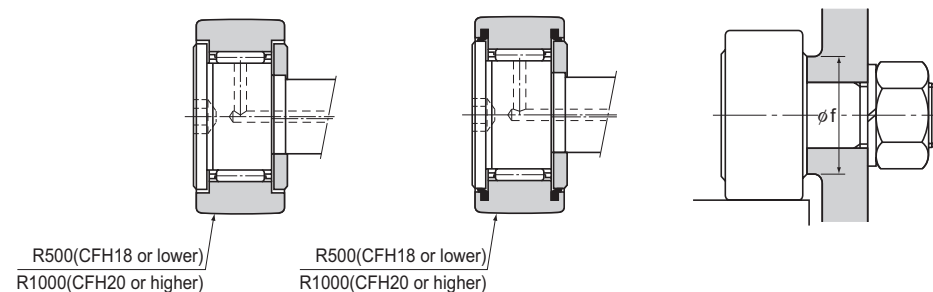
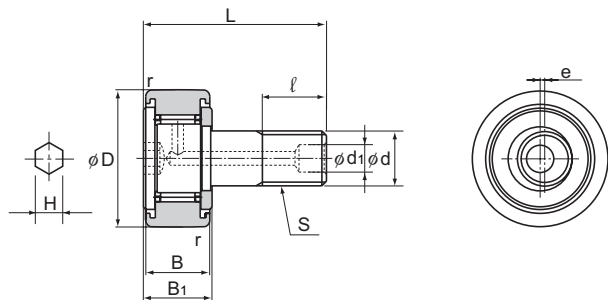

Model CFH-R

Model CFH-UUR

Unit: mm

Stud diameter d	Model No.	Main dimensions											Basic load rating				Maximum permissible load F ₀ kN	Track load capacity		Rotational speed limit [*]		Mass	
		Outer diameter D	Threaded S	Outer ring width B	B ₁	Overall length L	d ₁	ℓ	Runout e	H	r	Shoulder height f (Min.)	With cage		Full-roller type			Cylindrical outer ring kN	Spherical outer ring kN	With cage min ⁻¹	Full-roller type min ⁻¹	Cage g	Full rollers g
													C kN	C ₀ kN	C kN	C ₀ kN							
6	CFH 6-A	16	M6×1	11	12	28	—*	9	0.25	3	0.5	11	3.59	3.58	6.94	8.5	2.11	3.43	1.08	25000	11000	18.5	19
8	CFH 8-A	19	M8×1.25	11	12	32	—*	11	0.25	4	0.5	13	4.17	4.65	8.13	11.2	4.73	4.02	1.37	20000	8700	28.5	29
10	CFH 10-A	22	M10×1.25	12	13	36	—*	13	0.3	5	1	15	5.33	6.78	9.42	14.3	5.81	4.7	1.67	17000	7200	45	46
10	CFH 10-1-A	26	M10×1.25	12	13	36	—*	13	0.3	5	1	15	5.33	6.78	9.42	14.3	5.81	5.49	2.06	17000	7200	60	61
12	CFH 12-A	30	M12×1.5	14	15	40	6	14	0.4	6	1.5	20	7.87	9.79	13.4	19.8	9.37	7.06	2.45	14000	5800	95	97
12	CFH 12-1-A	32	M12×1.5	14	15	40	6	14	0.4	6	1.5	20	7.87	9.79	13.4	19.8	9.37	7.45	2.74	14000	5800	105	107
16	CFH 16-A	35	M16×1.5	18	19.5	52	6	18	0.5	6	1.5	24	12	18.3	20.6	37.6	17.3	11.2	3.14	10000	4500	170	173
18	CFH 18-A	40	M18×1.5	20	21.5	58	6	20	0.6	6	1.5	26	14.7	25.2	25.2	51.3	26.1	14.4	3.72	8500	3800	250	255
20	CFH 20-A	52	M20×1.5	24	25.5	66	8	22	0.7	8	1.5	36	20.7	34.8	33.2	64.8	32.1	23.2	8.23	7000	3400	460	465
20	CFH 20-1-A	47	M20×1.5	24	25.5	66	8	22	0.7	8	1.5	36	20.7	34.8	33.2	64.8	32.1	21	7.15	7000	3400	385	390
24	CFH 24-A	62	M24×1.5	29	30.5	80	8	25	0.8	8	1.5	40	30.6	53.2	46.7	92.9	49.5	34.2	10.5	6500	2900	815	820
24	CFH 24-1-A	72	M24×1.5	29	30.5	80	8	25	0.8	8	1.5	40	30.6	53.2	46.7	92.9	49.5	39.8	12.9	6500	2900	1140	1140
30	CFH 30-A	80	M30×1.5	35	37	100	8	32	1	8	2	46	45.4	87.6	67.6	145	73.7	52.6	14.9	5000	2300	1870	1870
30	CFH 30-1-A	85	M30×1.5	35	37	100	8	32	1	8	2	46	45.4	87.6	67.6	145	73.7	56	16.1	5000	2300	2030	2030
30	CFH 30-2-A	90	M30×1.5	35	37	100	8	32	1	8	2	46	45.4	87.6	67.6	145	73.7	59.3	17.3	5000	2300	2220	2220

Note) THK also manufactures types that have a driver groove and a greasing hole on the head. (Model numbers of types with a driver groove do not include symbol "A" in the end.)
 The seal must be used at temperature of 80°C or below.
 Those models marked with "*" do not have a greasing hole and cannot be replenished with grease.

Note) The rotation speed limit value in the table (*) applies to models that have no seal and use grease lubrication. With those models using oil lubrication, up to 130% of this value is permitted. With those attached with seals, up to 70% of this value is permitted.
 THK also manufactures full-roller types.

Model number coding

CFH24-1 M UU -A
 Model number | Stud with a hexagon socket
 Made of stainless steel | With seal

Model number coding

CFH12 UU R -A
 Model number | Stud with a hexagon socket
 With seal | Spherical outer ring