

Rotary Nut Series

Ball Screw/Spline

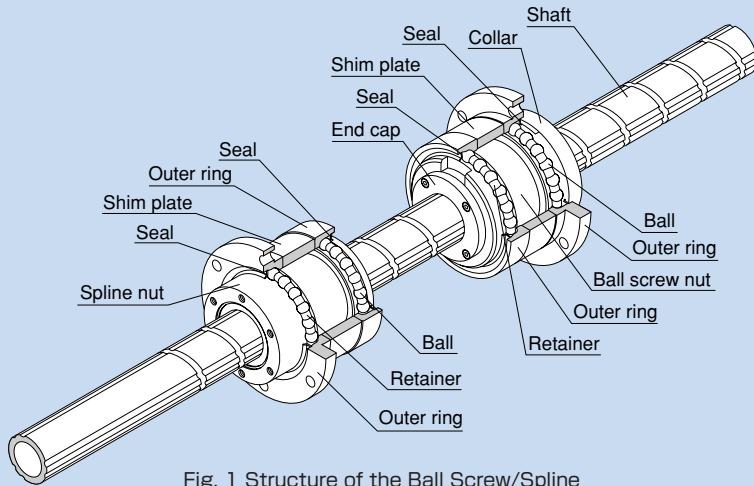

Fig. 1 Structure of the Ball Screw/Spline

● Structure and Features

The Ball Screw/Spline contains Ball Screw grooves and Ball Spline groove crossing one another. The nuts of the Ball Screw and the Ball Spline have dedicated support bearings directly embedded on the circumference of the nuts.

The Ball Screw/Spline is capable of performing three (rotational, linear and spiral) modes of motion with a single shaft by rotating or stopping the spline nut.

It is optimal for machines using a combination of rotary and linear motions, such as scholar robot's Z-axis, assembly robot, automatic loader, and machining center's ATC equipment.

● Zero Axial Clearance

The Ball Spline has an angular-contact structure that causes no backlash in the rotational direction, enabling highly accurate positioning.

● Lightweight and Compact

Since the ball screw nut is integrated with the support bearing, highly accurate, compact design is allowed. In addition, small inertia because of the lightweight ball screw nut ensures high responsiveness.

● Easy Installation

The Ball Spline nut is designed so that balls do not fall off even if the spline nut is removed from the shaft, making installation easy. The Ball Screw/Spline can easily be mounted simply by securing it to the housing with bolts (for the housing's inner-diameter tolerance, H7 is recommended).

● Smooth Motion with Low Noise

As the Ball Screw is based on an end-cap mechanism, smooth motion with low noise is achieved.

● Highly Rigid Support Bearing

The support bearing on the Ball Screw has a contact angle of 60° in the axial direction while that on the Ball Spline has a contact angle of 30° in the moment direction, thus to provide a highly rigid shaft support.

In addition, a dedicated rubber seal is attached as standard to prevent entry of foreign matter.

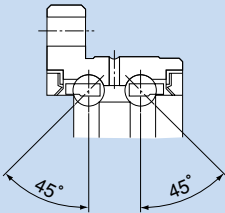

Fig. 2 Structure of Support Bearing Model BNS-A

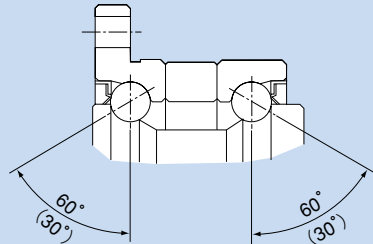

Fig. 3 Structure of Support Bearing Model BNS

● Types

Model BNS-A



(Compact type: linear motion + rotary motion)

Model BNS



(Heavy-load type: linear motion + rotary motion)

Model NS-A



(Compact type: linear motion)

Model NS



(Heavy-load type: linear motion)

Action Patterns

Model BNS Basic Actions

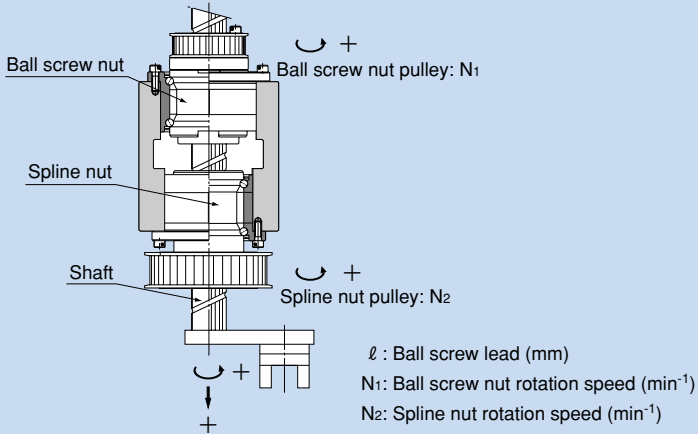

Motion	Action direction	Input		Shaft motion	
		Ball screw pulley	Ball spline pulley	Vertical direction (speed)	Rotational direction (rotation speed)
1. Vertical 	① Vertical direction → down Rotational direction → 0	N_1 (Forward)	0	$V=N_1 \cdot \ell$ ($N_1 \neq 0$)	0
	② Vertical direction → up Rotational direction → 0				
2. Rotation 	① Vertical direction → 0 Rotational direction → forward	N_1	N_2 (Forward)	0	N_2 (Forward) ($N_1=N_2 \neq 0$)
	② Vertical direction → 0 Rotational direction → reverse				
3. Spiral 	① Vertical direction → up Rotational direction → forward	0	N_2 ($N_2 \neq 0$)	$V=N_2 \cdot \ell$	N_2 (Forward)
	② Vertical direction → down Rotational direction → reverse				

Model NS Basic Actions

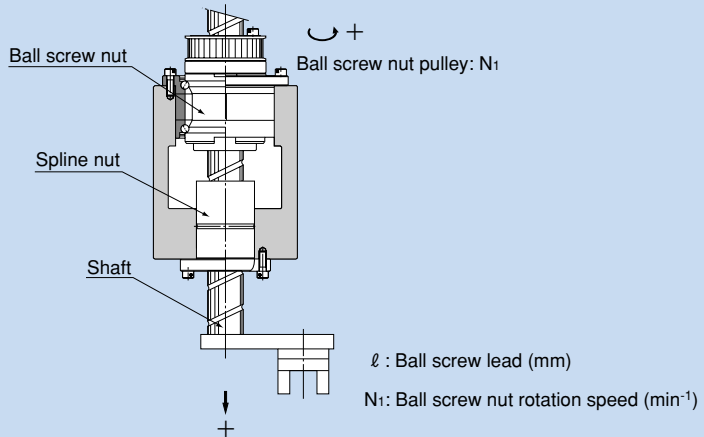

Motion	Action direction	Input Ball screw pulley	Shaft motion Vertical direction (speed)
1. Vertical 	① Vertical direction → down	N_1 (Forward)	$V = N_1 \cdot \ell$ ($N_1 \neq 0$)
	② Vertical direction → up	$-N_1$ (Reverse)	$V = -N_1 \cdot \ell$ ($N_1 \neq 0$)

Model BNS Extended Actions

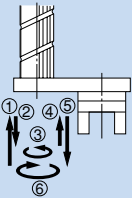
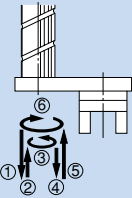
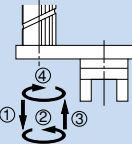
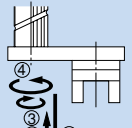
Motion	Action direction	Input		Shaft motion		
		Ball screw pulley	Ball spline pulley	Vertical direction (speed)	Rotational direction (rotation speed)	
1. Up → down → forward → up → down → reverse 	①	Vertical direction → up	$-N_1$ (Reverse)	0	$V = -N_1 \cdot \ell$ ($N_1 \neq 0$)	0
	②	Vertical direction → down	N_1 (Forward)	0	$V = N_1 \cdot \ell$ ($N_1 \neq 0$)	0
	③	Rotational direction → forward	N_1	N_2 (Forward)	0	N_2 (Forward) ($N_1 = N_2 \neq 0$)
	④	Vertical direction → up	$-N_1$	0	$V = -N_1 \cdot \ell$ ($N_1 \neq 0$)	0
	⑤	Vertical direction → down	N_1	0	$V = N_1 \cdot \ell$ ($N_1 \neq 0$)	0
	⑥	Rotational direction → reverse	$-N_1$	$-N_2$ (Reverse)	0	$-N_2$ (Reverse) ($-N_1 = N_2 \neq 0$)
2. Down → up → forward → down → up → reverse 	①	Vertical direction → down	N_1	0	$V = N_1 \cdot \ell$ ($N_1 \neq 0$)	0
	②	Vertical direction → up	$-N_1$	0	$V = -N_1 \cdot \ell$ ($N_1 \neq 0$)	0
	③	Rotational direction → forward	N_1	N_2	0	N_2 ($N_1 = N_2 \neq 0$)
	④	Vertical direction → up	N_1	0	$V = N_1 \cdot \ell$ ($N_1 \neq 0$)	0
	⑤	Vertical direction → down	$-N_1$	0	$V = -N_1 \cdot \ell$ ($N_1 \neq 0$)	0
	⑥	Rotational direction → reverse	$-N_1$	$-N_2$	0	$-N_2$ ($-N_1 = N_2 \neq 0$)
3. Down → forward → up → reverse 	①	Vertical direction → down	N_1	0	$V = N_1 \cdot \ell$ ($N_1 \neq 0$)	0
	②	Rotational direction → forward	N_1	N_2	0	N_2 ($N_1 = N_2 \neq 0$)
	③	Vertical direction → up	$-N_1$	0	$V = -N_1 \cdot \ell$ ($N_1 \neq 0$)	0
	④	Rotational direction → reverse	$-N_1$	$-N_2$	0	$-N_2$ ($-N_1 = N_2 \neq 0$)
4. Down → up → forward → reverse 	①	Vertical direction → down	N_1	0	$V = N_1 \cdot \ell$ ($N_1 \neq 0$)	0
	②	Vertical direction → up	$-N_1$	0	$V = -N_1 \cdot \ell$ ($N_1 \neq 0$)	0
	③	Rotational direction → reverse	$-N_1$	$-N_2$	0	$-N_2$ ($-N_1 = N_2 \neq 0$)
	④	Rotational direction → forward	N_1	N_2	0	N_2 ($N_1 = N_2 \neq 0$)

Example of Assembly

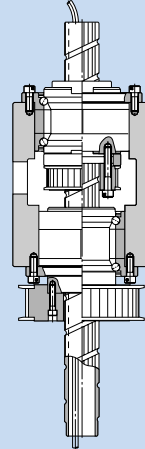
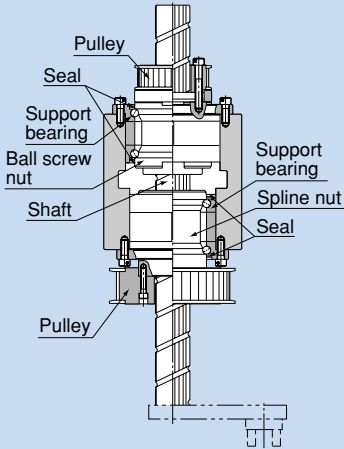

- Example of installing the ball screw nut and the spline nut input pulley both outside the housing. The housing length is minimized.

- Example of installing the ball screw nut pulley inside the housing.

Fig. 4 Example of Assembling Model BNS

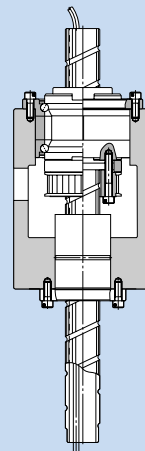
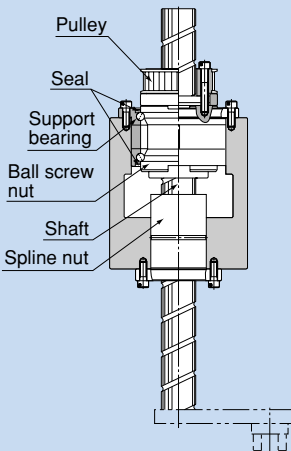

- Example of installing the ball screw nut pulley outside the housing. The housing length is minimized.

- Example of installing the ball screw nut pulley inside the housing.

Fig. 5 Example of Assembling Model NS

Accuracy

The Ball Screw/Spline is manufactured with the following specifications.

Ball Screw

Axial clearance: 0 or less

Lead accuracy : C5

(For detailed specifications, see page k-8.)

Ball Spline

Axial clearance: 0 or less (CL: light preload)

(For detailed specifications, see page b-4.)

Lead accuracy : class H

(For detailed specifications, see page b-5.)

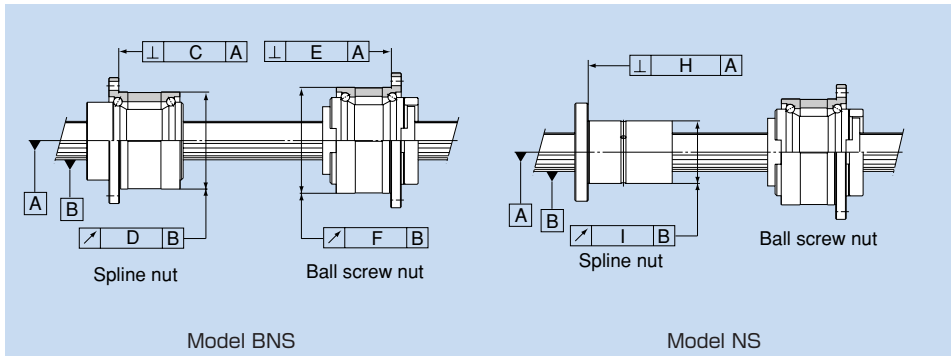

Unit: mm

Model No.	C	D	E	F	H	I
BNS 0812 NS 0812	0.014	0.017	0.014	0.016	0.010	0.013
BNS 1015 NS 1015	0.014	0.017	0.014	0.016	0.010	0.013
BNS 1616 NS 1616	0.018	0.021	0.016	0.020	0.013	0.016
BNS 2020 NS 2020	0.018	0.021	0.016	0.020	0.013	0.016
BNS 2525 NS 2525	0.021	0.021	0.018	0.024	0.016	0.016
BNS 3232 NS 3232	0.021	0.021	0.018	0.024	0.016	0.016
BNS 4040 NS 4040	0.025	0.025	0.021	0.033	0.019	0.019
BNS 5050 NS 5050	0.025	0.025	0.021	0.033	0.019	0.019

Example of Use

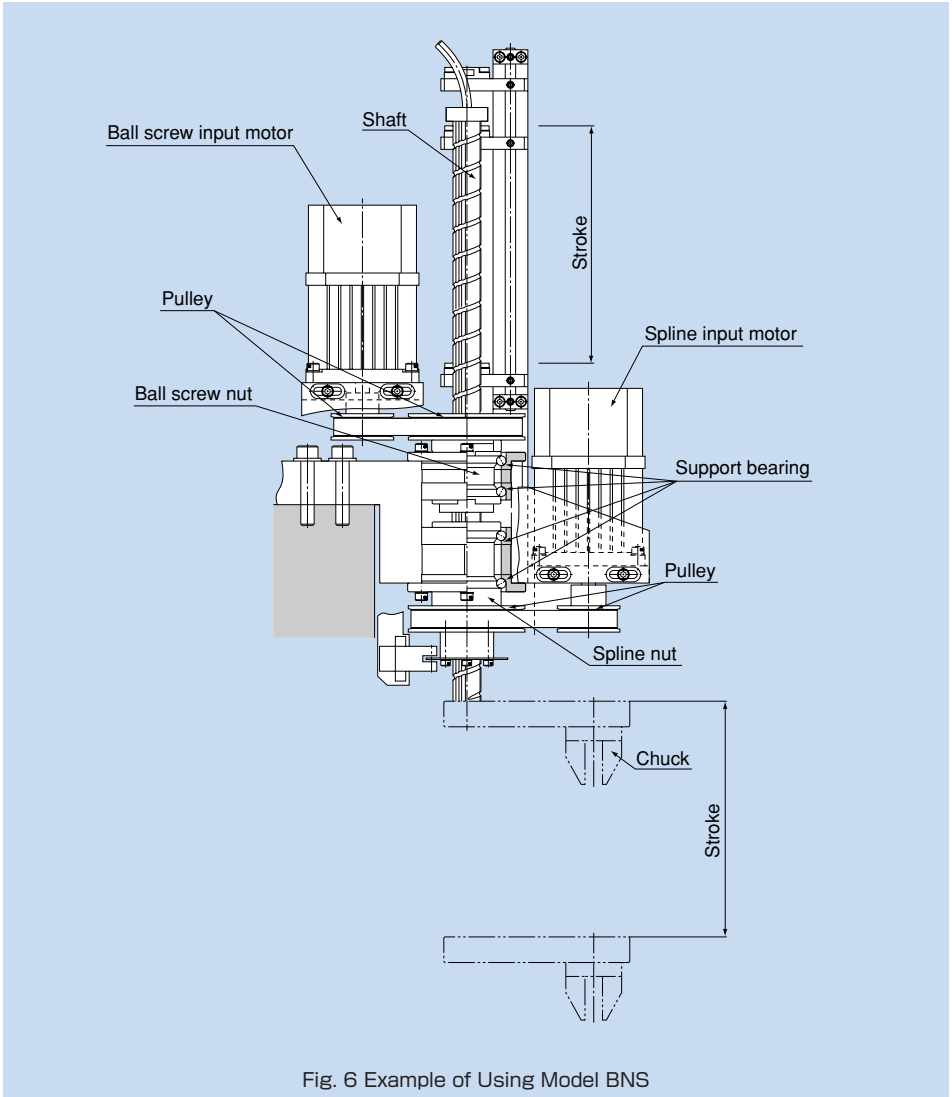
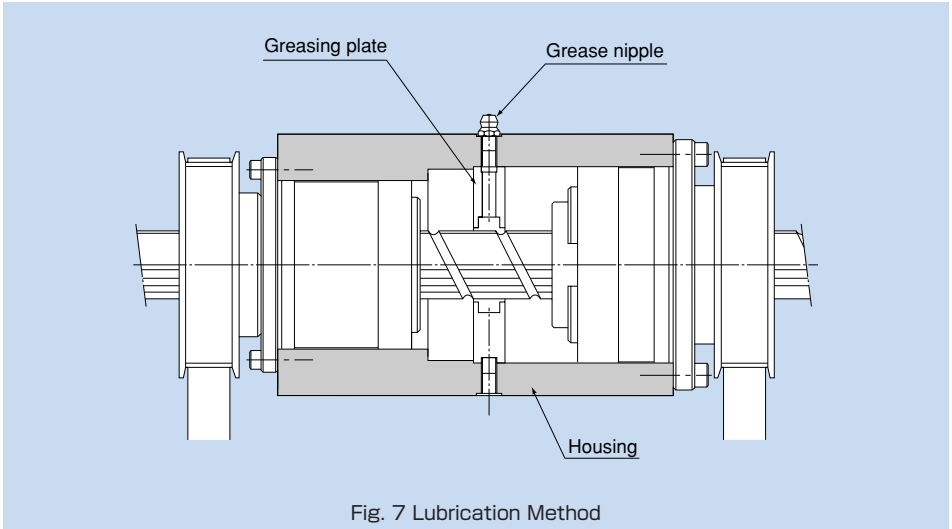

Fig. 6 Example of Using Model BNS

Precautions on Use

Lubrication

When lubricating the Ball Screw/Spline, attach the greasing plate to the housing in advance.



Model BNS-A

Compact Type: Linear Motion + Rotary Motion

k. Dimensions of the Ball Screw

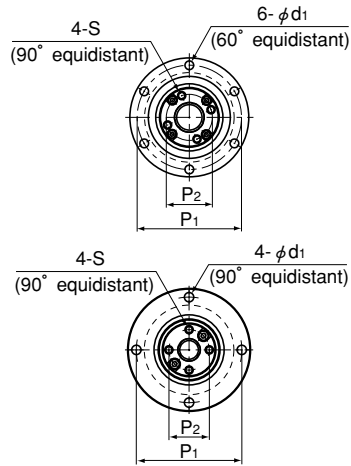

Models BNS 0812A and 1015A

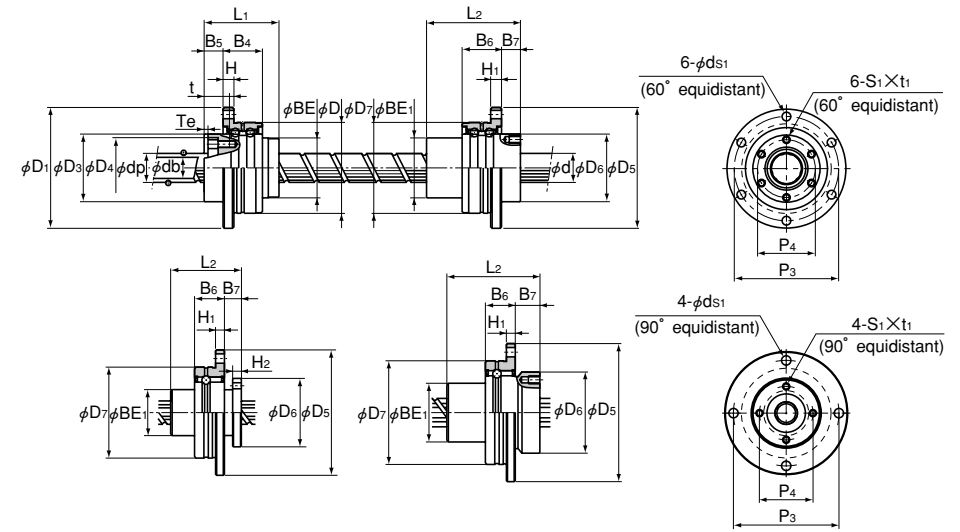

Model BNS 0812A

Model BNS 1015A

Models BNS 0812A and 1015A

Unit: mm

Model No.	Screw shaft outer diameter d	Screw shaft inner diameter dp	Lead R	Ball screw dimensions											Support bearing basic load rating		Nut inertial moment kg·cm ²	Screw shaft inertial moment J kg·cm ² /mm								
				Ca kN	C _{0a} kN	Ball center diameter dp	Thread minor diameter dc	Outer diameter D g6	Flange diameter D ₁	Overall length L ₁	D ₃ h7	D ₄ H7	BE	H	B ₄	B ₅			Te	P ₁	P ₂	S	t	d ₁	Ca kN	C _{0a} kN
BNS 0812A	8	—	12	1.1	1.8	8.4	6.6	32	44	28.5	22	19	19	3	10.5	7	1.5	38	14.5	M2.6	10	3.4	0.8	0.5	0.03	3.16×10 ⁻⁵
BNS 1015A	10	—	15	1.7	2.7	10.5	8.3	36	48	34.5	26	23	23	3	10.5	8	1.5	42	18	M3	11.5	3.4	0.9	0.7	0.08	7.71×10 ⁻⁵
BNS 1616A	16	11	16	3.9	7.2	16.65	13.7	48	64	40	36	32	32	6	21	10	2	56	25	M4	13.5	4.5	8.7	10.5	0.35	3.92×10 ⁻⁴
BNS 2020A	20	14	20	6.1	12.3	20.75	17.5	56	72	48	43.5	39	39	6	21	11	2.5	64	31	M5	16.5	4.5	9.7	13.4	0.85	9.37×10 ⁻⁴
BNS 2525A	25	18	25	9.1	19.3	26	22	66	86	58	52	47	47	7	25	13	3	75	38	M6	20	5.5	12.7	18.2	2.12	2.2×10 ⁻³
BNS 3232A	32	23	32	13	29.8	33.25	28.3	78	103	72	63	58	58	8	25	14	3	89	48	M6	21	6.6	13.6	22.3	5.42	5.92×10 ⁻³
BNS 4040A	40	29	40	21.4	49.7	41.75	35.2	100	130	88	79.5	73	73	10	33	16.5	3	113	61	M8	24.5	9	21.5	36.8	17.2	1.43×10 ⁻²

Model No.	Ball spline dimensions										Support bearing basic load rating				Nut inertial moment kg·cm ²						
	C kN	C ₀ kN	Permissible static moment M _A N·m	C _T N·m	C _{0T} N·m	Outer diameter D ₇ g6	Flange diameter D ₅	Overall length L ₂	D ₆ h7	BE ₁	H ₁	B ₆	B ₇	H ₂		P ₃	P ₄	S ₁ ×t ₁	d _{s1}	C kN	C ₀ kN
BNS 0812A	1.5	2.6	5.9	2	2.9	32	44	25	24	16	3	10.5	6	3	38	19	M2.6×3	3.4	0.6	0.2	0.03
BNS 1015A	2.7	4.9	15.7	3.9	7.8	36	48	33	28	21	3	10.5	9	—	42	23	M3×4	3.4	0.8	0.3	0.08
BNS 1616A	7.1	12.6	67.6	31.4	34.3	48	64	50	36	31	6	21	10	—	56	30	M4×6	4.5	6.7	6.4	0.44
BNS 2020A	10.2	17.8	118	56.8	55.8	56	72	63	43.5	35	6	21	12	—	64	36	M5×8	4.5	7.4	7.8	0.99
BNS 2525A	15.2	25.8	210	105	103	66	86	71	52	42	7	25	13	—	75	44	M5×8	5.5	9.7	10.6	2.2
BNS 3232A	20.5	34	290	180	157	78	103	80	63	52	8	25	17	—	89	54	M6×10	6.6	10.5	12.5	5.17
BNS 4040A	37.8	60.5	687	418	377	100	130	100	79.5	64	10	33	20	—	113	68	M6×10	9	16.5	20.7	16.1

Model number coding

BNS2020A +500L

1

2

1 Model number 2 Overall shaft length (in mm)

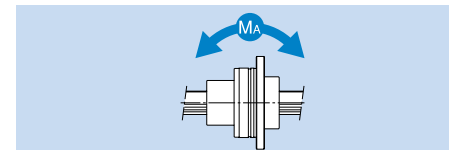

Model BNS

Heavy-load Type: Linear Motion + Rotary Motion

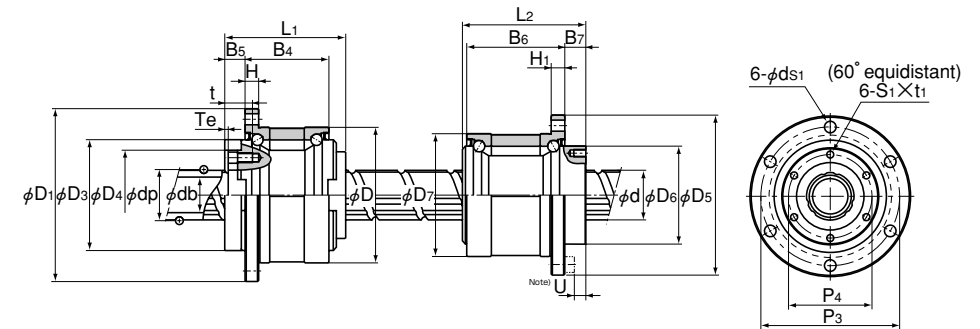
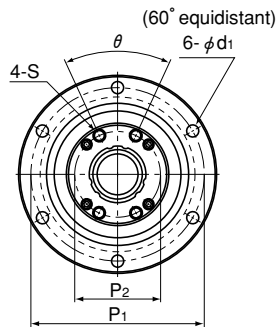

Unit: mm

Model No.	Screw shaft outer diameter d	Screw shaft inner diameter dp	Lead R	Ball screw dimensions												Support bearing basic load rating		Nut inertial moment kg·cm ²	Screw shaft inertial moment J kg·cm ² /mm							
				Ca kN	Coa kN	Ball center diameter dp	Thread minor diameter dc	Outer diameter D	Flange diameter D1	Overall length L1	D3 h7	D4 H7	H	B4	B5	Te	P1			P2	S	t	d1	θ°	Ca kN	Coa kN
BNS 1616	16	11	16	3.9	7.2	16.65	13.7	52 ⁰ _{-0.007}	68	43.5	40	32	5	27.5	9	2	60	25	M4	12	4.5	40	19.4	19.2	0.48	3.92×10 ⁻⁴
BNS 2020	20	14	20	6.1	12.3	20.75	17.5	62 ⁰ _{-0.007}	78	54	50	39	6	34	11	2	70	31	M5	16	4.5	40	26.8	29.3	1.44	9.37×10 ⁻⁴
BNS 2525	25	18	25	9.1	19.3	26	22	72 ⁰ _{-0.007}	92	65	58	47	8	43	12.5	3	81	38	M6	19	5.5	40	28.2	33.3	3.23	2.2×10 ⁻³
BNS 3232	32	23	32	13	29.8	33.25	28.3	80 ⁰ _{-0.007}	105	80	66	58	9	55	14	3	91	48	M6	19	6.6	40	30	39	6.74	5.92×10 ⁻³
BNS 4040	40	29	40	21.4	49.7	41.75	35.2	110 ⁰ _{-0.008}	140	98	90	73	11	68	16.5	3	123	61	M8	22	9	50	59.3	74.1	27.9	1.43×10 ⁻²
BNS 5050	50	36	50	31.8	77.6	52.2	44.1	120 ⁰ _{-0.008}	156	126	100	90	12	80	25	4	136	75	M10	28	11	50	62.2	83	58.2	3.52×10 ⁻²

Model No.	Basic load rating			Permissible static moment MA N·m			Basic torque rating			Ball spline dimensions			Support bearing basic load rating					Nut inertial moment kg·cm ²		
	C kN	Co kN	MA N·m	CT N·m	CoT N·m	Outer diameter D7	Flange diameter D5	Overall length L2	D6 h7	H1	B6	B7	P3	P4	S1×t1	ds1	U		C kN	Co kN
BNS 1616	7.1	12.6	67.6	31.4	34.3	52 ⁰ _{-0.007}	68	50	39.5	5	37	10	60	32	M5×8	4.5	5	12.7	11.8	0.52
BNS 2020	10.2	17.8	118	56.8	55.8	56 ⁰ _{-0.007}	72	63	43.5	6	48	12	64	36	M5×8	4.5	7	16.2	15.5	0.87
BNS 2525	15.2	25.8	210	105	103	62 ⁰ _{-0.007}	78	71	53	6	55	13	70	45	M6×8	4.5	8	17.6	18	1.72
BNS 3232	20.5	34	290	180	157	80 ⁰ _{-0.007}	105	80	65.5	9	60	17	91	55	M6×10	6.6	10	20.1	24	5.61
BNS 4040	37.8	60.5	687	418	377	100 ⁰ _{-0.008}	130	100	79.5	11	74	23	113	68	M6×10	9	13	37.2	42.5	14.7
BNS 5050	60.9	94.5	1340	842	768	120 ⁰ _{-0.008}	156	125	99.5	12	97	25	136	85	M10×15	11	13	41.6	54.1	62.5

Note Dimension U indicates the length from the head of the hexagon socket bolt to the ball screw nut end.

Model number coding

BNS2525 +600L

1 2

1 Model number 2 Overall shaft length (in mm)

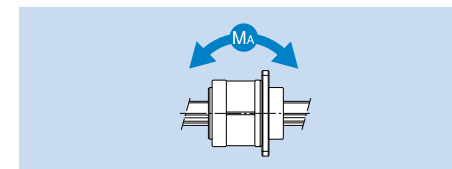

Model NS-A

Compact Type: Linear Motion

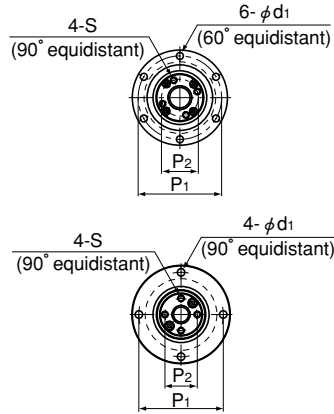

Models NS 0812A and 1015A

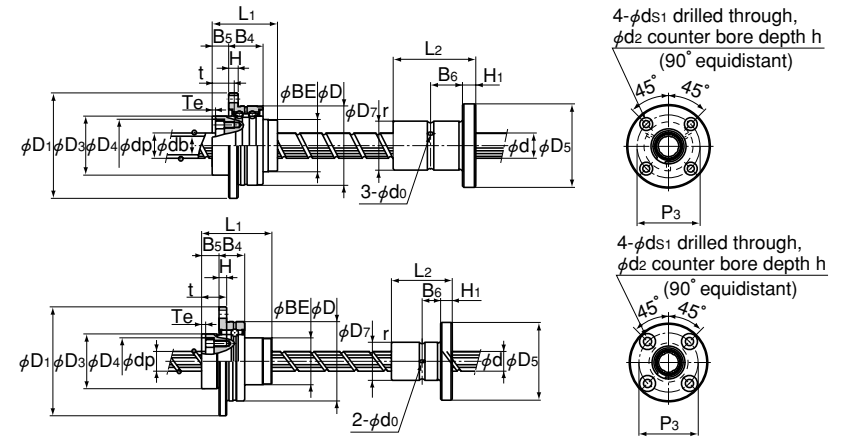

Models NS 0812A and 1015A

Unit: mm

Model No.	Screw shaft outer diameter d	Screw shaft inner diameter dp	Lead R	Ball screw dimensions										Support bearing basic load rating		Nut inertial moment kg·cm ²	Screw shaft inertial moment J kg·cm ² /mm									
				Ca kN	C _{0a} kN	Ball center diameter dp	Thread minor diameter dc	Outer diameter D g6	Flange diameter D ₁	Overall length L ₁	D ₃ h7	D ₄ H7	BE	H	B ₄			B ₅	Te	P ₁	P ₂	S	t	d ₁	Ca kN	C _{0a} kN
NS 0812A	8	—	12	1.1	1.8	8.4	6.6	32	44	28.5	22	19	19	3	10.5	7	1.5	38	14.5	M2.6	10	3.4	0.8	0.5	0.03	3.16×10 ⁻⁵
NS 1015A	10	—	15	1.7	2.7	10.5	8.3	36	48	34.5	26	23	23	3	10.5	8	1.5	42	18	M3	11.5	3.4	0.9	0.7	0.08	7.71×10 ⁻⁵
NS 1616A	16	11	16	3.9	7.2	16.65	13.7	48	64	40	36	32	32	6	21	10	2	56	25	M4	13.5	4.5	8.7	10.5	0.35	3.92×10 ⁻⁴
NS 2020A	20	14	20	6.1	12.3	20.75	17.5	56	72	48	43.5	39	39	6	21	11	2.5	64	31	M5	16.5	4.5	9.7	13.4	0.85	9.37×10 ⁻⁴
NS 2525A	25	18	25	9.1	19.3	26	22	66	86	58	52	47	47	7	25	13	3	75	38	M6	20	5.5	12.7	18.2	2.12	2.2×10 ⁻³
NS 3232A	32	23	32	13	29.8	33.25	28.3	78	103	72	63	58	58	8	25	14	3	89	48	M6	21	6.6	13.6	22.3	5.42	5.92×10 ⁻³
NS 4040A	40	29	40	21.4	49.7	41.75	35.2	100	130	88	79.5	73	73	10	33	16.5	3	113	61	M8	24.5	9	21.5	36.8	17.2	1.43×10 ⁻²

Model No.	Basic load rating		Permissible static moment M _A N·m	Basic torque rating		Outer diameter D ₇	Flange diameter D ₅₋₈₂	Overall length L ₂	H ₁	B ₆	r	Greasing hole d ₀	P ₃	Mounting hole		
	C kN	C ₀ kN		C _T N·m	C _{0T} N·m									d _{s1}	d ₂	h
NS 0812A	1.5	2.6	5.9	2	2.9	16 ⁰ _{-0.011}	32	25	5	7.5	0.5	1.5	24	3.4	6.5	3.3
NS 1015A	2.8	4.9	15.7	3.9	7.8	21 ⁰ _{-0.013}	42	33	6	10.5	0.5	1.5	32	4.5	8	4.4
NS 1616A	7.1	12.6	67.6	31.4	34.3	31 ⁰ _{-0.013}	51	50 ⁰ _{-0.2}	7	18	0.5	2	40	4.5	8	4.4
NS 2020A	10.2	17.8	118	56.8	55.8	35 ⁰ _{-0.016}	58	63 ⁰ _{-0.2}	9	22.5	0.5	2	45	5.5	9.5	5.4
NS 2525A	15.2	25.8	210	105	103	42 ⁰ _{-0.016}	65	71 ⁰ _{-0.3}	9	26.5	0.5	3	52	5.5	9.5	5.4
NS 3232A	20.5	34	290	180	157	49 ⁰ _{-0.016}	77	80 ⁰ _{-0.3}	10	30	0.5	3	62	6.6	11	6.5
NS 4040A	37.8	60.5	687	418	377	64 ⁰ _{-0.019}	100	100 ⁰ _{-0.3}	14	36	0.5	4	82	9	14	8.6

Model number coding

NS2020A +500L

1

2

1 Model number 2 Overall shaft length (in mm)

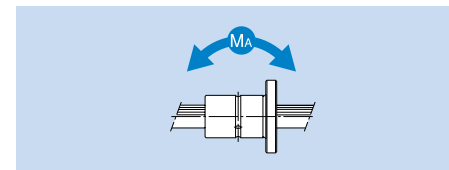

Model NS

Heavy-load Type: Linear Motion

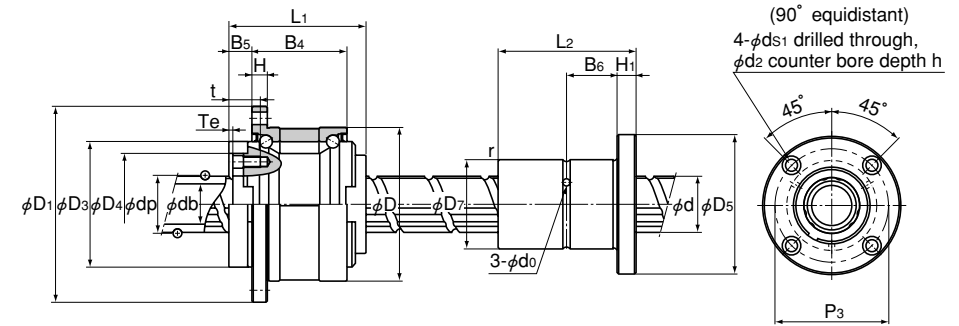
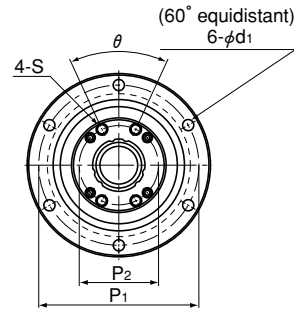

Unit: mm

Model No.	Screw shaft outer diameter d	Screw shaft inner diameter dp	Lead R	Ball screw dimensions										Support bearing basic load rating		Nut inertial moment kg·cm ²	Screw shaft inertial moment J kg·cm ² /mm									
				Ca kN	C _{0a} kN	Ball center diameter dp	Thread minor diameter dc	Outer diameter D	Flange diameter D ₁	Overall length L ₁	D ₃ h7	D ₄ H7	H	B ₄	B ₅			T _e	P ₁	P ₂	S	t	d ₁	θ°	Ca kN	C _{0a} kN
NS 1616	16	11	16	3.9	7.2	16.65	13.7	52 ⁰ _{-0.007}	68	43.5	40	32	5	27.5	9	2	60	25	M4	12	4.5	40	19.4	19.2	0.48	3.92×10 ⁻⁴
NS 2020	20	14	20	6.1	12.3	20.75	17.5	62 ⁰ _{-0.007}	78	54	50	39	6	34	11	2	70	31	M5	16	4.5	40	26.8	29.3	1.44	9.37×10 ⁻⁴
NS 2525	25	18	25	9.1	19.3	26	22	72 ⁰ _{-0.007}	92	65	58	47	8	43	12.5	3	81	38	M6	19	5.5	40	28.2	33.3	3.23	2.2×10 ⁻³
NS 3232	32	23	32	13	29.8	33.25	28.3	80 ⁰ _{-0.007}	105	80	66	58	9	55	14	3	91	48	M6	19	6.6	40	30	39	6.74	5.92×10 ⁻³
NS 4040	40	29	40	21.4	49.7	41.75	35.2	110 ⁰ _{-0.008}	140	98	90	73	11	68	16.5	3	123	61	M8	22	9	50	59.3	74.1	27.9	1.43×10 ⁻²
NS 5050	50	36	50	31.8	77.6	52.2	44.1	120 ⁰ _{-0.008}	156	126	100	90	12	80	25	4	136	75	M10	28	11	50	62.2	83	58.2	3.52×10 ⁻²

Model No.	Basic load rating		Permissible static moment M _A N·m	Basic torque rating		Outer diameter D ₇	Flange diameter D ₅	Overall length L ₂	H ₁	B ₆	r	Greasing hole d ₀	Mounting hole			
	C kN	C ₀ kN		C _T N·m	C _{0T} N·m								P ₃	d _{s1}	d ₂	h
NS 1616	7.1	12.6	67.6	31.4	34.3	31 ⁰ _{-0.013}	51	50 ⁰ _{-0.2}	7	18	0.5	2	40	4.5	8	4.4
NS 2020	10.2	17.8	118	56.9	55.9	35 ⁰ _{-0.016}	58	63 ⁰ _{-0.2}	9	22.5	0.5	2	45	5.5	9.5	5.4
NS 2525	15.2	25.8	210	105	103	42 ⁰ _{-0.016}	65	71 ⁰ _{-0.3}	9	26.5	0.5	3	52	5.5	9.5	5.4
NS 3232	20.5	34	290	180	157	49 ⁰ _{-0.016}	77	80 ⁰ _{-0.3}	10	30	0.5	3	62	6.6	11	6.5
NS 4040	37.8	60.5	687	419	377	64 ⁰ _{-0.019}	100	100 ⁰ _{-0.3}	14	36	0.5	4	82	9	14	8.6
NS 5050	60.9	94.5	1340	842	769	80 ⁰ _{-0.019}	124	125 ⁰ _{-0.3}	16	46.5	1	4	102	11	17.5	11

Model number coding

NS2525 +600L



1 Model number 2 Overall shaft length (in mm)

